

Product Features

- Pb-Ca-Sn multi-components alloy.
- High purity electrolysis lead,high density lead paste,special long effective additive.
- High adsorptive performance AGM separator.
- Excellent cycle life and recoverage performance from over-discharged state.
- Excellent large current discharge performance, there is obvious advantage in start-up and climbing slope stage.
- Good large current discharge performance, good low temperature endurance and shock endurance.
- Maintenance free, there is no need to add water during operation.

Application

- Electrical Vehicle
- Mixture Electrical vehicle
- Sightseeing car
- Golf car
- Electrical transit car
- Electrical patrol car
- Public project car
- Electrical tractor
- Property maintenance car
- Electrical flat car
- Electrical freight car
- Electrical drone car

Compliant Standards

- ☒ GB/T 18332.1-2009
- ☒ IEC 61982-3 2001-06
- ☒ GB/T 7403.1-2008
- ☒ GB/T 23636-2009
- ☒ GB/T 18332.1-2009
- ☒ Passed ISO9001:2000 、 ISO14001 、 OHSAS18001、 UL、 CE certificate

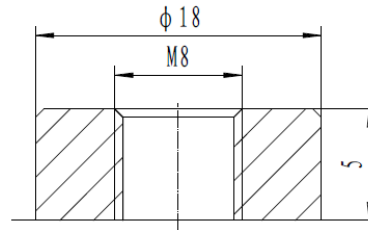
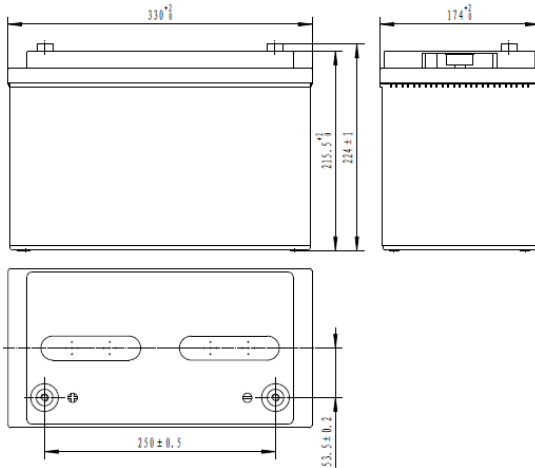

Battery Model	6-DM-110			
Designed Life	700times (80%DOD)			
Capacity(25°C)	20HR(5.7A,1.75V)	10HR(11.3A,1.75V)	5HR(22A,1.75V)	1HR(73A,1.75V)
	114Ah	113AH	110AH	73AH
Dimensions	Length	Width	Height	Total Height
	330mm	175mm	215mm	224mm
Approx. Weight	35kg			
Internal Resistance	5.0m Ω			
Maximum Discharge Current	900A(10 Sec.)			
Self Discharge	≤3% per months (25°C)			
Charge Voltage(25°C)	Cycle use		Float use	
	14.7V(-18mV/°C), max charge current:15A		14.1V(-18mV/°C)	

Discharge parameter:

Constant current discharge data (25°C, A)											
End voltage (V/cell)	10min	20min	30min	45min	60min	90min	2h	3h	5h	10h	20h
1.60	274.3	160.3	120.5	89.63	75.92	59.76	47.20	33.97	22.40	11.48	5.780
1.65	268.1	157.1	118.6	88.19	74.83	59.15	46.83	33.83	22.31	11.45	5.768
1.70	261.0	153.3	116.0	86.60	74.02	58.61	46.50	33.63	22.18	11.38	5.734
1.75	255.0	150.5	114.0	85.33	73.00	57.93	46.00	33.33	22.00	11.30	5.700

Constant power discharge data (25°C, W/cell)											
End voltage (V/cell)	10min	20min	30min	45min	60min	90min	2h	3h	5h	10h	20h
1.60	481.8	288.7	221.5	167.3	146.8	117.0	93.45	67.93	44.83	23.04	11.63
1.65	479.6	287.3	220.6	166.4	145.3	116.3	92.88	67.72	44.69	23.01	11.61
1.70	473.5	283.6	218.2	165.1	144.3	115.6	92.37	67.38	44.50	22.89	11.55
1.75	469.0	281.9	216.8	164.3	143.0	114.6	91.54	66.89	44.18	22.77	11.50

All data on the spec. sheet is an average value:

The tolerance range: $X < 6\text{min}$ (+15%~-15%), $6\text{min} \leq X < 10\text{min}$ (+12%~-12%), $10\text{min} \leq X < 60\text{min}$ (+8%~-8%), $X \geq 60\text{min}$ (+5%~-5%)

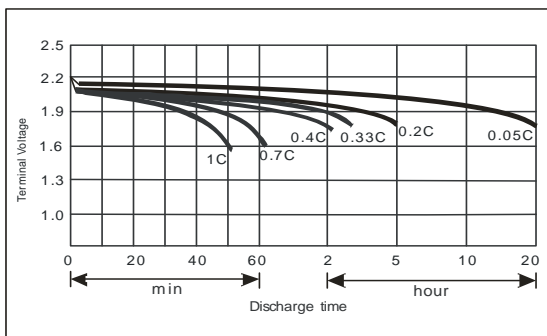
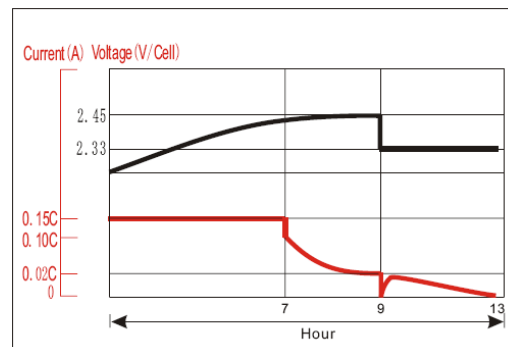
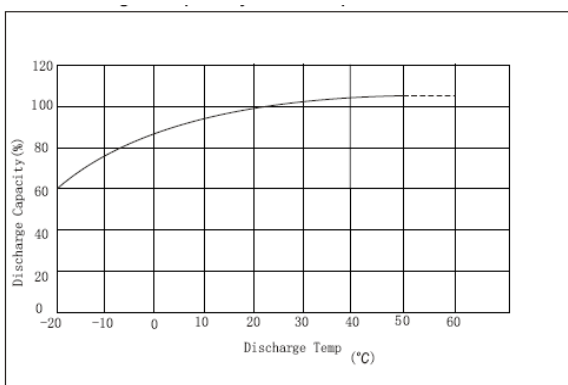
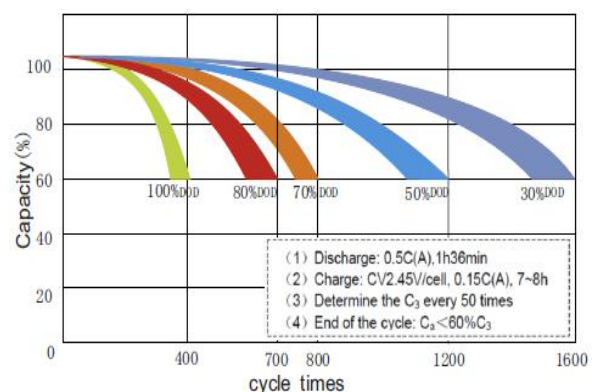
Performance Curve :

Discharge performance

Charge performance

Discharge capacity Vs temperature

Cycle life Vs discharge depth

Address: NO.1 Shenyang Road, Qufu, Shandong 273100 China

Tel: +86-537-4438666-6028

Fax: +86-537-4411936

E-mail: sales@sacredsun.cn

http://www.sacredsun.com